

AP-K2N CRIMPING MACHINE

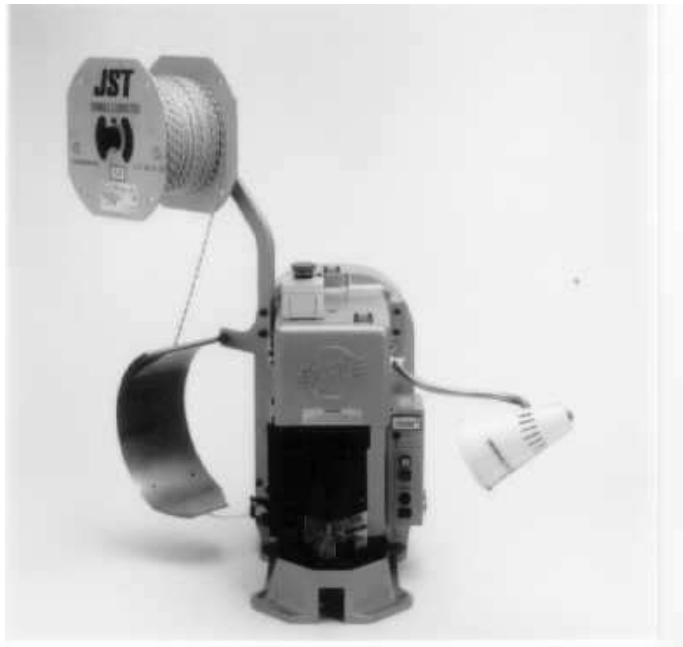

OPERATION

MANUAL

JST
The Quality Connection

PREFACE

The AP-K2N semi-automatic crimping machine is easy to operate, and is suitable for mass production of crimped harnesses with chain terminals.

Before using the AP-K2N please read this manual to ensure that you are familiar with the features of the machine and the layout of the operating controls. We recommend that you always keep this manual near the machine to use for reference when required. This manual also contains information on maintenance, fault-finding and adjustment of the crimping machine and its associated tooling.

For safe operation

- THIS MACHINE IS A POWER PRESS AND SHOULD NEVER BE USED WITHOUT THE SAFETY GUARDS FITTED.
- If you think that something is wrong with the machine, immediately turn OFF the machine and disconnect the lead from the power supply. Guards must only be removed by an authorised person during setting, adjustment and maintenance.
- The maximum measured sound output generated by the Crimping Press is 86 dB. It is recommended that ear defenders are worn whilst operating the machine.
- Do not modify or adapt the machine without prior consent of JST.
- This crimping machine complies with the CE directive for machinery and has the **CE** mark affixed to indicate its compliance.
- This crimping machine must not be incorporated into other machinery without the consent of JST (ref. The Supply of Machinery (safety) Regulations 1992, S.I 1992/3073).

Table of Contents

1. SPECIFICATIONS.....	4
1 - 1 Crimping Machine Specifications.....	4
1 - 2 Applicator Specifications.....	4
2. INSTALLING AND TRANSPORTING THE MACHINE.....	5
2 - 1 Installation.....	5
2 - 2 Transporting.....	5
3. PREPARATION FOR OPERATION.....	6
3 - 1 Mounting the Reel Hanger.....	6
3 - 2 Mounting the Applicator.....	6
3 - 3 Mounting the Terminal Reel.....	7
3 - 4 Mounting the Safety Guard.....	8
4. CONTROL BOX CONFIGURATION.....	12
5. OPERATION.....	13
5 - 1 Manual Operation.....	13
5 - 2 Operation under Power.....	14
6. APPLICATOR.....	15
6 - 1 Terminal Feed Position Adjustment.....	15
6 - 2 Bell Mouth Adjustment.....	16
6 - 3 Feed-finger Travel Adjustment.....	17
6 - 4 Crimp Adjustment.....	17
6 - 5 Die Part Replacement.....	18
6 - 6 Lubrication of Applicator.....	18
7. CRIMPING MACHINE MAINTENANCE.....	19
7 - 1 Lubrication.....	19
7 - 2 Inspection and Repair.....	21
8. FAULT FINDING.....	22
9. EXPLODED VIEWS AND PARTS LISTS.....	26
AP-K2N Crimping Machine Exploded Diagram.....	26
MK-L Applicator.....	28
MKS-L Applicator.....	30
MKF-L Applicator.....	32
MKS-LS Applicator.....	34

1. SPECIFICATIONS

The crimping machine is composed of the crimping press and an applicator. There are two basic types of applicators (a total of four models).

Models MK-L and MKF-L for end feeding terminals, and models MKS-L and MKS-LS for side feeding terminals. The crimping machine utilizes a quick change system thus allowing quick change-over times.

1.1 Crimping Machine Specifications



- Model no: AP-K2N
- ⊗ External dimensions: 280mm Wide x 480mm Long x 560mm High
 - ⊗ Weight: 90 Kg
 - ⊗ Power supply: 220/240V AC single phase 50/60 Hz
 - ⊗ Power consumption: 680VA
 - ⊗ Crimping force: 1500 Kg
 - ⊗ Ram stroke: 30mm
 - ⊗ Ram speed: 260 strokes per minute (60 Hz), and 220 strokes per minute (50 Hz)
 - ⊗ Closed height: 160.0 mm ± 0.01 at B.D.C

1.2 Applicator specifications

Model no. MK-L (for-end feeding terminals)

- ⊗ Weight 6.8 Kg
- ⊗ Feed pitch 30mm max.
- ⊗ Crimp height adjustment: Dial type

Model no. MKS-L (for side-feeding terminals)

- ⊗ Weight 6.4 Kg
- ⊗ Feed pitch 30mm max.
- ⊗ Crimp height adjustment: Dial type

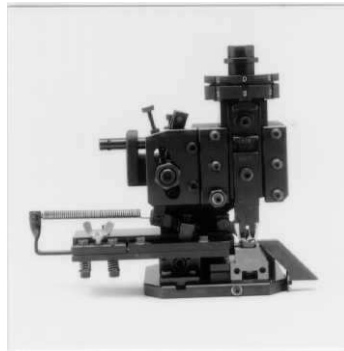

Model no. MKF-L (for-end feeding flag terminals)

- ⊗ Weight 6.8 Kg
- ⊗ Feed pitch 30mm max.
- ⊗ Crimp height adjustment: Dial type

Model no. MKS-LS (for side feeding terminals)

- ⊗ Weight 4.5 Kg
- ⊗ Feed pitch 30mm max.
- ⊗ Crimp height adjustment: Dial type

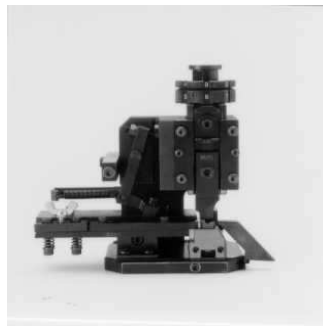
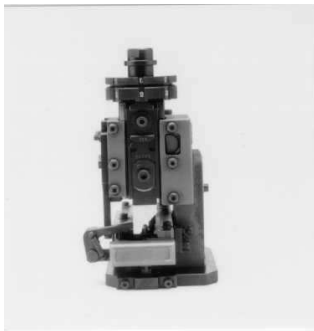

2 INSTALLING AND TRANSPORTING THE MACHINE

2.1 Installation

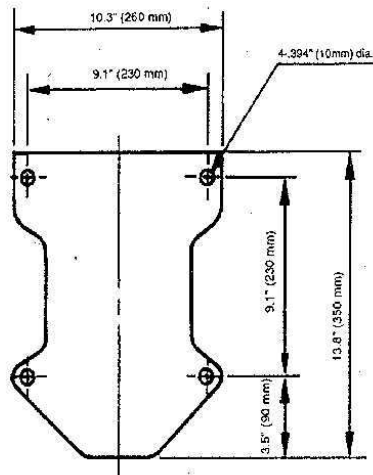

Mount the crimping machine on a solid foundation, place a rubber mat between the machine and foundation to reduce vibration and stabilize the machine.

The diagram to the left illustrates the footprint dimensions of the machine. Secure the machine to the foundation with four M8 bolts.

The machine should be mounted so that the crimping dies are at the approximate eye level of a seated operator.

CAUTION

Ensure that the belt cover of the crimping machine does not overhang the edge of the mounting surface.

2.2 Transporting



Always mount the handles supplied with the toolbox to move the machine (as shown in the photograph on the left).

The machine should always be transported by placing the lifting handles onto the arms of a fork-lift truck.

DO NOT ATTEMPT TO LIFT MANUALLY.

3. PREPARING FOR OPERATION

3.1 Mounting the Reel Hanger

Due to packing considerations, when you receive the machine the reel hanger is not mounted on the machine. Assemble the reel hanger then mount it on the machine as illustrated below.



3.2 Mounting the applicator (All types)

Step 1

Loosen bolts A & B with a 5mm hexagon wrench supplied with the tool-kit.

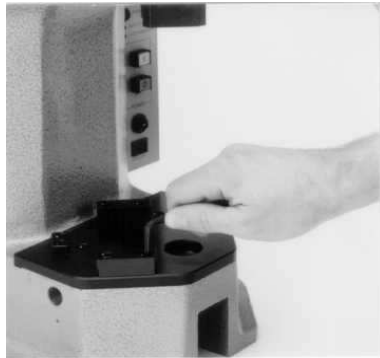

Step 2

Remove the protective rubber collar from under the dials on the applicator ram.



Step 3

Place the applicator on the base-plate of the crimping machine. Pull up the applicator ram whilst simultaneously pushing the feed lever in the direction of the arrow shown in the photograph below, so that the collar on the shank slides into the groove on the press ram. Then push the applicator fully back into the press.

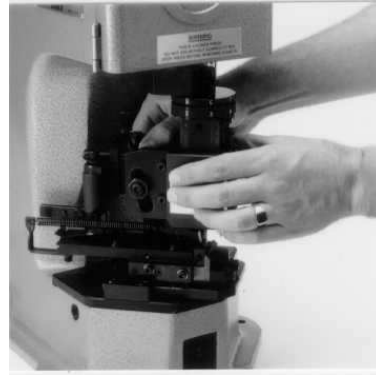

CAUTION

ENSURE THAT THE SHANK IS CORRECTLY LOCATED IN THE RAM. THERE IS A DANGER OF MAJOR TOOLING DAMAGE IF THE TOOLING IS NOT LOCATED CORRECTLY (AS IN THE PHOTOGRAPH BELOW).

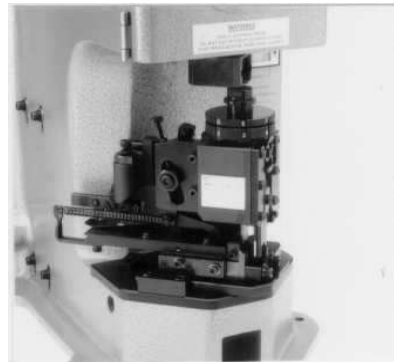

Step 4

Securely fasten the clamps with the 5 mm hexagon key, and visually check that the tooling is mounted correctly.



3.3 Mounting the Terminal Reel

Mount the terminal reel to the reel hanger so that the terminal barrels are facing the reel guide, then feed the terminals through the terminal guide to the applicator.



Mounting the MKS-L or MKS-LS Applicator

Step 1

Rotate the wing bolt clockwise to raise the pressure plate. Feed the terminal strip between the guide rails.

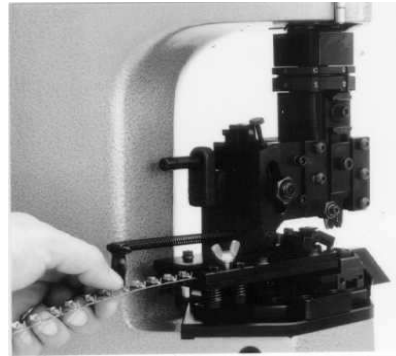

Mounting the MK-L Applicator

Step 1

Push down the tension lever and engage the hook with the feed plate so that the pressure pad rises. Feed the terminal strip between the guide rails.

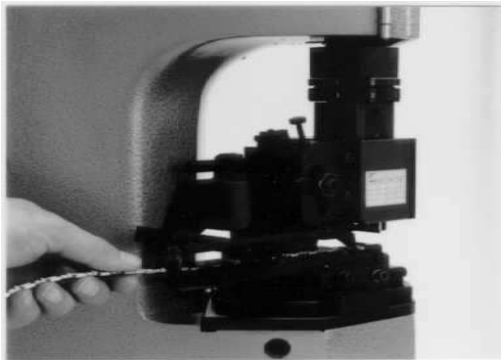

Step 2

Place the first terminal in position so that the terminal is centralised over the anvil. Rotate the wing bolt counter-clockwise to lower the pressure plate so that pressure is applied to the terminal.

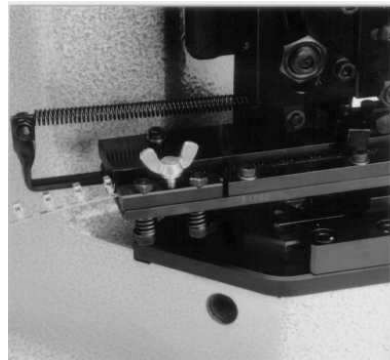

Step 2

Place the first terminal at the correct crimping position. Release the hook from the feed plate to allow the pressure pad to apply pressure on the strip.

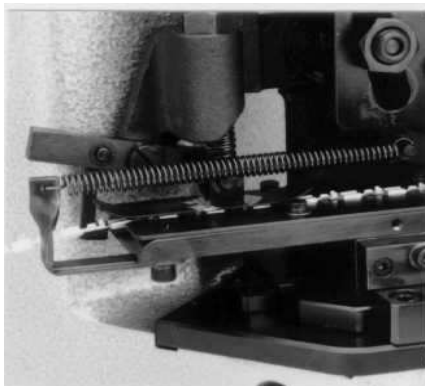
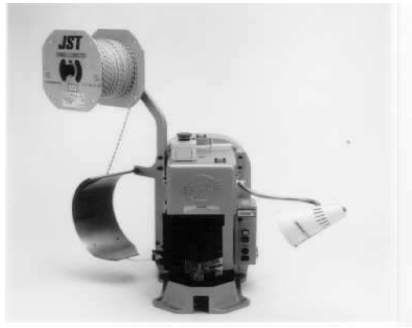
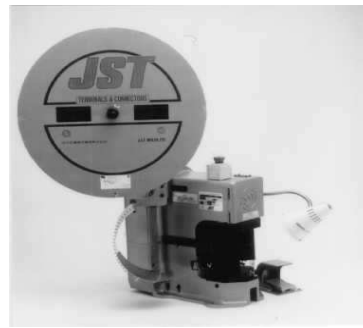

Illustration of Terminal reels mounted on the AP-K2N Crimping Machine



MK-L



MKS-L

3.4 Mounting the safety guard

For reasons of safety and to comply with legislation, safety guards must always be mounted to the crimping machine. The above photographs illustrate the AP-K2N crimping machine with the safety guards fitted.

The following photographs illustrate the different types of guards available for the range of JST applicators.

WARNING

**AN AUTHORISED COMPETENT PERSON
MUST ONLY CARRY OUT THE
FOLLOWING OPERATIONS.**

When using the MK-L Applicator.

Step 1

Secure the fabricated steel guard (JST UK-7), onto the Applicator using the cap head socket screws supplied.



Step 2

Secure the die guard (JST UK-1), onto the applicator using the cap head socket screws supplied.

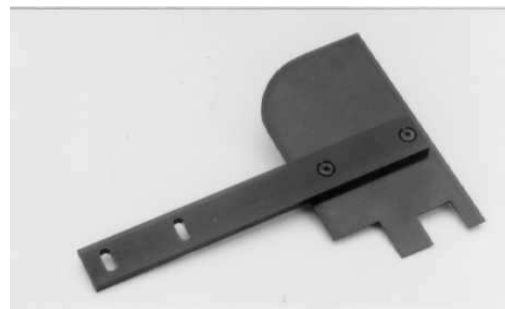

Step 4

Remove the two upper motor fixing screws and clamp the side guard support bracket onto the press utilising these screws.

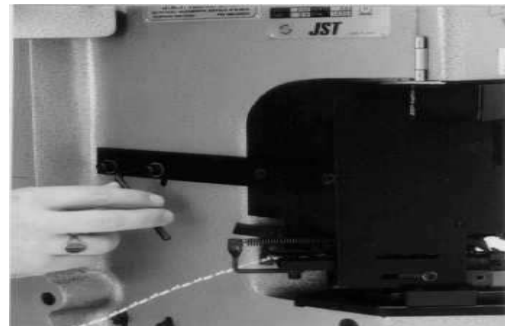

Step 5

Adjust the side guard support to achieve the best relationship between guard and applicator.

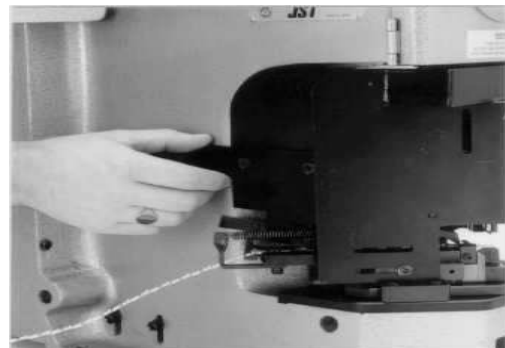

Step 6
Tighten the screws and check that the guards are correctly and securely fitted.



Step 4
Remove the two upper motor fixing screws and clamp the side guard support bracket onto the press utilizing these screws.

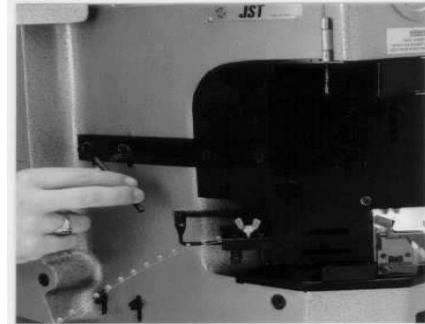

When using the MKS-L Applicator

Step 1
Secure the fabricated steel guard (JST UK-7), to the applicator using the cap head socket screws supplied.



Step 5
Adjust the side guard support to achieve the best relationship between guard and applicator.

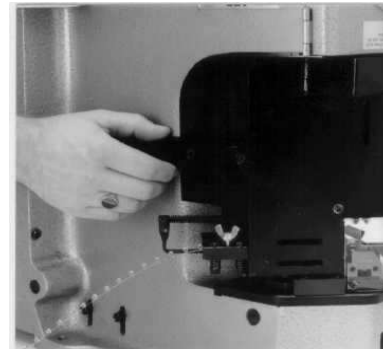

Step 2
Secure the die guard (JST UK-6), onto the applicator using the cap head socket screws supplied.



Step 6
Tighten the screws and check that the guards are correctly and securely fitted.

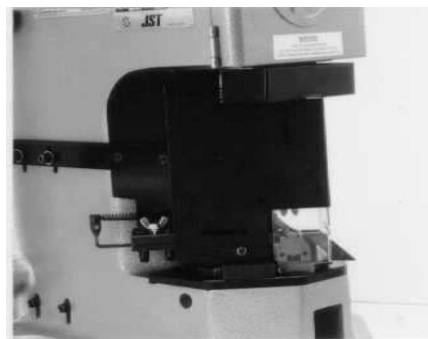

Step 3
Select the appropriate side guard (JST UK-3), and mount onto the side guard support bracket (JST UK-9), using the countersunk screws provided.

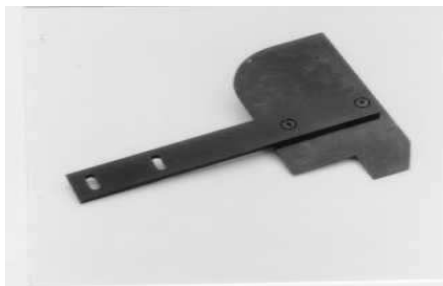

When using the MKS-L Applicator for SPC or PSL splices

Step 1

Secure the fabricated steel guard (JST UK-17), to the applicator using the cap head screws supplied.



Step 4

Remove the two upper motor fixing screws and clamp the side guard support bracket onto the press utilizing these screws.

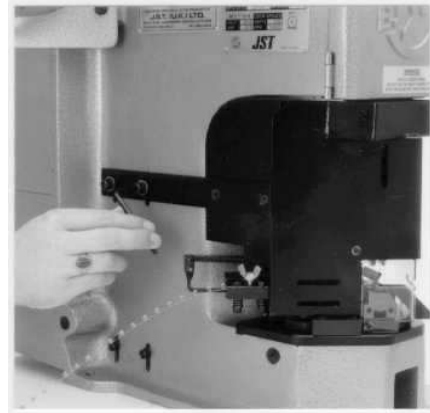

Step 2

Secure the fabricated steel guard (JST UK-135), onto the side face of the applicator using the cap head screws supplied.



Step 5

Adjust the side guard support bracket to achieve the best relationship between guard and applicator.



Step 3

Select the appropriate side guard (JST UK-3), and mount onto the side guard support bracket (JST UK-9), using the countersunk screws supplied..



Step 6

Tighten the screws and check that the guards are correctly and securely fitted.



When using the MKF-L Applicator

Step 1

Secure the fabricated steel guard (JST UK-35), to the applicator using the cap head screw supplied.



Step 2

Select the appropriate side guard (JST UK-95), and mount onto the side guard support bracket (JST UK-9), using the countersunk screws supplied.

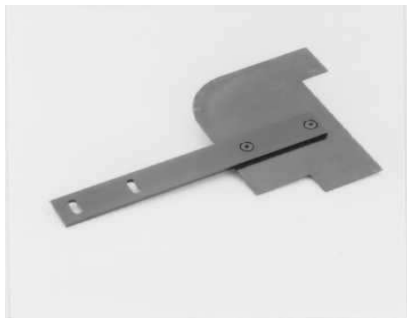

Step 3

Remove the two upper motor fixing screws and clamp the side guard support bracket onto the press utilizing these screws.

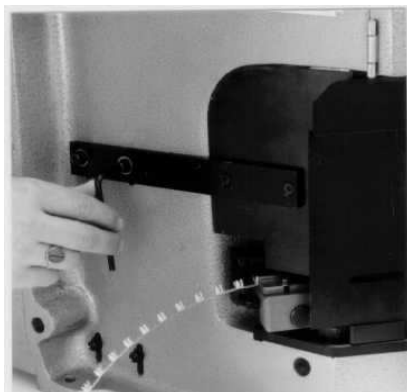

Step 4

Adjust the side guard support bracket to achieve the best relationship between guard and applicator.

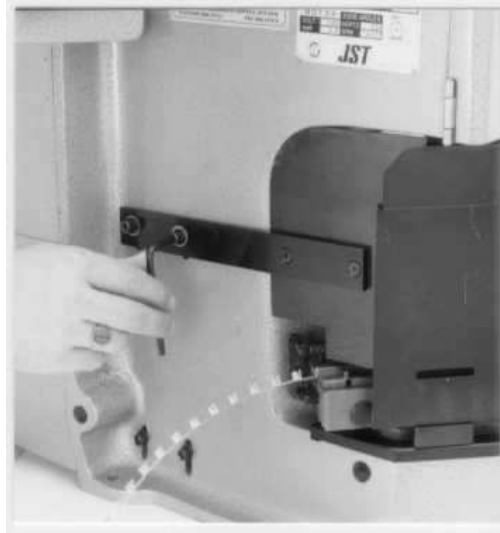

Step 5

Tighten the screws and check that the guards are correctly and securely fitted.

IMPORTANT

If the safety guards become damaged or worn they must be replaced immediately. Please contact the JST Technical Department for replacement guards.

4. CONTROL BOX CONFIGURATION

1. Counter

Counts the number of crimped terminations. Reset the counter to 0 to begin counting operations.

2. Reset Push-button

Press this button to reset the counter (resets the counter to 0)

3. Function Indicator Lamps

- Rear Cover
The rear cover indicator lamp is lit when the belt-cover is open. Whilst this lamp is lit, the motor does not operate even if the Power On push-button is pushed.

CAUTION

DO NOT OPEN THE BELT COVER WHILST MOTOR IS RUNNING, BECAUSE THE FLYWHEEL CONTINUES TO ROTATE FOR A FEW SECONDS AFTER THE MOTOR IS TURNED OFF DUE TO INERTIA STORED IN THE FLYWHEEL.

- Auto Power-Off
When the crimping operation stops for a period of approximately 3 minutes or more, for example when you unintentionally leave the motor running after finishing work or temporarily stop the operation, the motor automatically stops and the Auto Power-off indicator lamp illuminates.

If the Rear Cover indicator illuminates, close the cover and press the Power On push-button to restart. If the Auto Power Off indicator illuminates, just press the Power On push-button to restart.

4. Power On Push-button (green Indicator Lamp)

Press this button to turn on the motor. The green indicator lamp illuminates and stays lit whilst the motor is running.

5. Power Off Push-button (Red Indicator Lamp)

Press this button to turn off the motor. The red Power Off indicator lamp illuminates.

6. Circuit Protector Push-button (Thermal Overload device)

When the crimping machine is overloaded, the Circuit Protector push-button 'pops out', and the motor stops. Wait for at least one minute, press the Circuit Protector Push-button in, then press the Power On push-button. Contact the JST Service Department if you think that the Circuit Protector is activated too often because the press may require attention.

7. Operation Light Switch (Ope. Light)

This switch controls the Worklamp. Press it to the right to turn the light on, and to the left to turn it off. The lamp-bulb is rated at 40 Watts and is of the 'Rough Service' type. Do not exceed 40 Watts because the surface temperature of the worklamp exceeds the maximum recommended temperature.

1. COUNTER
2. RESET
3. FUNCTION INDICATOR LAMPS
4. POWER ON PUSH-BUTTON (GREEN)
5. POWER OFF PUSH-BUTTON (RED)
6. CIRCUIT PROTECTOR PUSH-BUTTON
7. OPERATION LAMP SWITCH



5. OPERATION

WARNING

Disconnect the press from the power supply before operating by hand. Operations by hand whilst guards are removed must only be performed by authorized competent persons.

5.1 Manual Operation

CAUTION

When using an applicator for the first time after fitting it in the press, or whenever a die-part is replaced or the applicator is adjusted, ensure that the press is manually cycled at least one revolution. This is a very important operation to ensure that the terminals are crimped correctly and it also allows a degree of 'feel' through the crank handle which prevents major tooling damage from occurring if the die-parts have been installed incorrectly.

Step 1

Remove the cap head socket screws from the ram cover using the hexagon key supplied with the tool-kit, and open the belt cover.

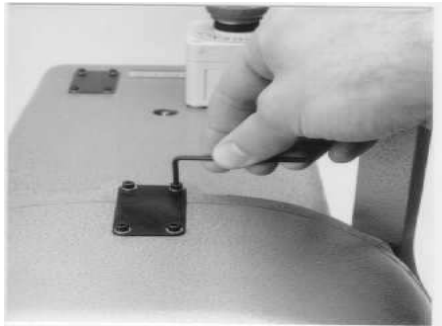

Step 2

Manually operate the solenoid by pushing the clutch lever in a downward direction until the clutch 'clicks'.

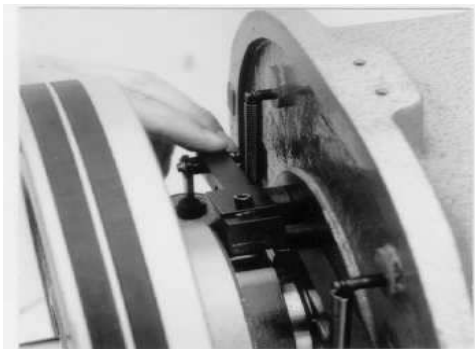

Step 3

Place the hand-crank supplied in the press tool-kit on the end of the main shaft and rotate in a counter-clockwise direction to manually cycle the press through one revolution. The ram moves up and down one stroke and crimps the terminal.



Step 4

Remove the hand-crank, close the belt cover and replace the cap head socket screw in the catch and tighten with the hexagon key.



CAUTION Ensure that hand-crank is rotated through one complete revolution (until it physically stops). If the press is left part-way through a cycle it will try to complete the cycle when the motor is turned on and this action could result in damage being caused to the tooling.

5.2 OPERATION

Step 1

Connect the power supply cable and the foot-switch cable to the control box using the screw in connectors. Connect the power supply cable to the mains supply and switch on the press.

CAUTION

Ensure that the power supply cable is routed from the press safely and does not become trapped or chafed by any part of the crimping machine.



Step 2

Press the Ope. Light to the right to turn on the Operation Light.



Step 3

To count the number of crimped terminations, press the Reset push-button to set the counter display to 0.



Step 4

Check that neither of the function indicators is illuminated, then press the Power On push-button (green). The motor starts running.

NOTE: If a malfunction indicator is illuminated the motor will not start even if you press the Power On push-button.



Step 5

Position a wire over the terminal and press the foot-switch once to activate it. The terminal is crimped and the next terminal is indexed along over the anvils ready for the next operation.



Step 6

When you finish using the press, turn off the Work-lamp and press the Power Off push-button.



CAUTION

If any problems occur during operations, immediately press the Power Off push-button and investigate the reason. If the problem requires the removal of safety guards, contact a person authorised to remove the guards. ON NO ACCOUNT REMOVE SAFETY GUARDS IF YOU ARE NOT AUTHORISED TO DO SO.

6. APPLICATOR ADJUSTMENT

6.1 Terminal Feed Position Adjustment.

CAUTION

The following adjustments require the removal of the safety guards and must only be carried out by authorized competent persons.

There is a risk of serious crushing injury in tooling exposed by the removal of the safety guards . Ensure that fingers are kept away from the moving parts of the applicator.

When using the MK-L Applicator

Adjust the terminal feed position to adjust the terminal crimping position. Before making this adjustment be sure that the applicator is mounted in the crimping machine correctly and the press ram is at Top Dead Centre. Loosen the 5mm cap head socket screw and the knurled collar using a small length of silver steel or similar, as indicated on the photograph.

With the aid of the silver steel or a flat ended screw-driver rotate the adjustment shaft so that the feed-finger places the terminal in the correct position for crimping. Rotate the shaft counter-clockwise to move the terminal forward, and clock-wise to move it backwards. When the adjustments are completed, tighten the knurled collar first followed by the cap screw.

Rotate the press through one revolution manually (see page 10), and check the resultant crimped terminal. If the appearance of the terminal is not correct repeat the above adjustment operation and check again.

When a satisfactory result is achieved, replace the guards, connect the crimping machine to the power supply and recommence the crimping operation.

When using the MKS-L Applicator

Adjust the terminal feed position to adjust the terminal crimping position. Before making this adjustment be sure that the applicator is mounted in the crimping machine correctly and the press ram is at Top Dead Centre.

To position a terminal at the centre of the die, follow the procedure below.

Loosen the 5mm cap head socket screw and the knurled collar using a small length of silver steel or similar, as indicated on the photograph.

With the aid of the silver steel or a flat ended screw-driver rotate the adjustment shaft so that the feed-finger places the terminal in the correct position for crimping. Rotate the shaft counter-clockwise to move the terminal to the right (forwards), and clock-wise to move it to the left (backwards).

When the adjustments are completed, tighten the knurled collar first followed by the cap screw.

Rotate the press through one revolution manually (see page 10), and check the resultant crimped terminal. If the appearance of the terminal is not correct repeat the above adjustment operation and check again.

When a satisfactory result is achieved, replace the guards, connect the crimping machine to the power supply and recommence the crimping operation.

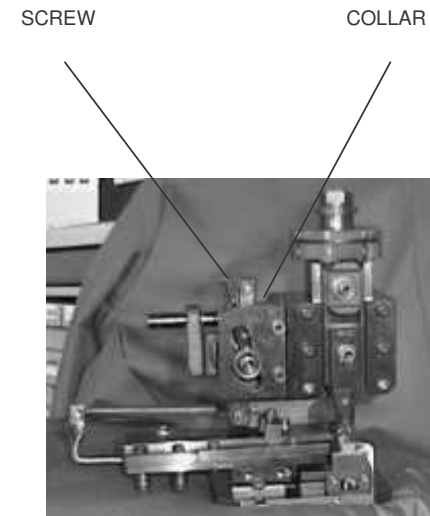
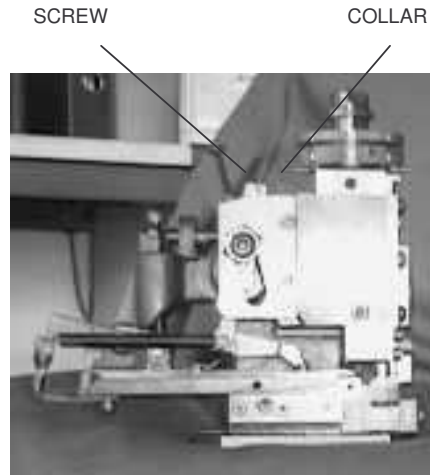

6.2 Bell Mouth Adjustment

When using the MK-L Applicator

Adjust the terminal feed position with reference to the bell-mouth position. Refer to section 6.1

When using the MKS-L Applicator (old type)

Move the entire feed-plate to obtain the desired bell-mouth crimp. First, loosen the feed-finger retaining screw in the feed-finger holder. Next, loosen the two cap head socket screws in the slots on the base of the applicator (see photograph).

With the aid of a flat ended screwdriver, rotate the adjusting screw in the front of the adjustment carriage, turn the screw clockwise to increase the bell-mouth (move the guide rails towards the front of the press), and counter-clockwise to decrease the bell-mouth (move the guide rails towards the back of the press).

Re-tighten the adjustment screws on the base of the applicator, centralize the feed-finger in the slot in the guide rail and tighten the screw.

Check the bell-mouth on the resultant crimp and re-adjust if necessary.

Slot-head adjustment screws

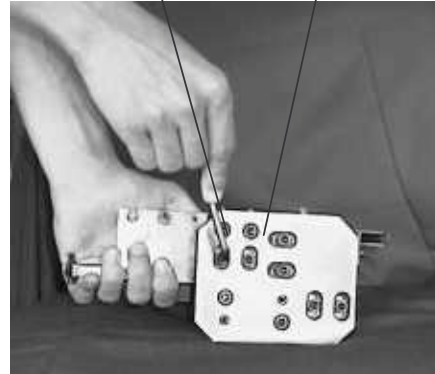

Feed-finger screw

Adjustment screw

When using the MKS-L Applicator (new type)

Move the entire feed-plate to obtain the desired bell-mouth crimp. First, loosen the feed-finger retaining screw in the feed-finger holder. Next, loosen the two hexagon-headed bolts situated on the front of the adjustment carriage just above the top surface of the applicator base-plate.

With the aid of a 5mm hexagon key, rotate the screw in the front of the adjustment carriage, turn the screw clockwise to decrease the bell-mouth (move the guide rails towards the back of the press), and counter-clockwise to increase the bell-mouth (move the guide rails towards the front of the press).

Re-tighten the adjustment bolts, centralize the feed-finger in the slot in the guide rail and tighten the screw.

Check the resultant crimp and re-adjust if necessary.

There is a crimping manual available from the JST Technical Department detailing the points to inspect on a crimped terminal to achieve results as per our specifications.

A copy is issued with every AP-K2N Crimping machine supplied to a customer but please contact JST if you require further copies.

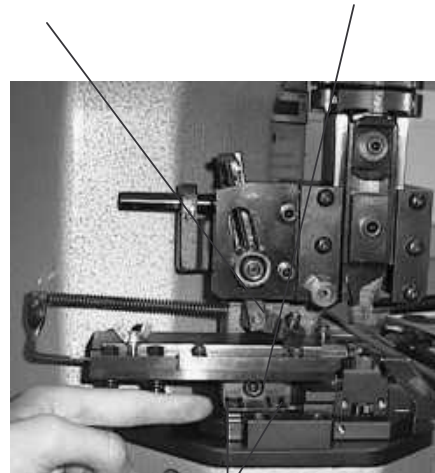

Hexagon nuts

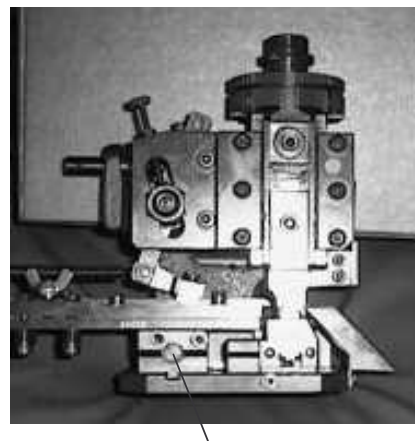

6.3 Feed-finger travel adjustment

Applicators are assembled and adjusted prior to despatch from JST and will not require adjustment by customers. Please contact JST Technical Services Department if you consider there is a problem with the Pitch setting adjustment.

6.4 Crimp Height adjustment

The applicator has two dials to adjust the insulation and wire crimp-height. The upper dial, marked with letters A - H, is for the wire (conductor), crimp-height. The lower dial, marked with numbers 1 - 8, is for the insulation crimp height.

JST do not advise pad settings for wire sizes, as is the practice of some manufacturers. We believe that the best method to adopt is to specify crimp-heights and adjust the dials until the desired crimp-height is achieved.

◻ Wire crimp-height (conductor) adjustment.

Setting the upper dial to graduation A produces the tightest crimp-height (lowest), and graduation H the least tight (highest). The crimp height alters by approximately 0.05mm per graduation, so a total range of adjustment of 0.40mm is attainable.

◻ Insulation crimp-height adjustment.

Setting the lower dial to graduation 1 produces the tightest crimp-height (lowest), and graduation 8 the least tight (highest). The crimp-height alters by approximately 0.10mm per graduation, so a total range of 0.80mm is attainable.

We do not state insulation crimp-heights due to the large variation of insulation types available. The insulation should be set as per instructed in the JST Crimping Manual supplied with the AP-K2N crimping machine. If you require further copies, please contact the JST Technical Services Department.

CAUTION

When initially installing the applicator in the press, ensure that the dials are set at H - 8 to avoid the possibility of tooling damage.

Always check the crimp-height of the terminal by use of a Crimp-height Micrometer because they are designed specifically for the purpose and indicate the true crimp-height. If you require details for the supply of a crimp-height micrometer please contact JST Technical Services Department.

If the applicator is not capable of achieving the desired crimp-height by adjusting the dials, please contact the JST Technical Services Department, because there is a range of blocks available to alter the range of crimp heights available. If you specify the blocks currently installed in your applicator (see 'Exploded view' supplied with applicator), we can advise you of the part no of the replacement blocks necessary to achieve the desired crimp-height.

Do not adjust the crimp-height by altering the shut-height of the AP-K2N press, because it is factory set and should only require occasional adjustment when serviced by the JST Service Engineer.

INSULATION CRIMP ADJUSTING DIAL
CONDUCTOR CRIMP ADJUSTING DIAL

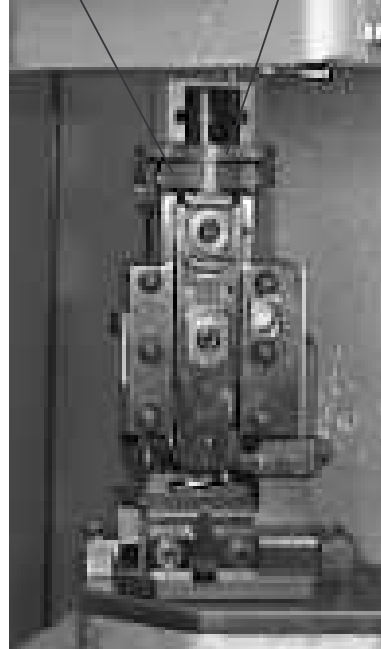

MK-L

INSULATION CRIMP ADJUSTING DIAL
CONDUCTOR CRIMP ADJUSTING DIAL

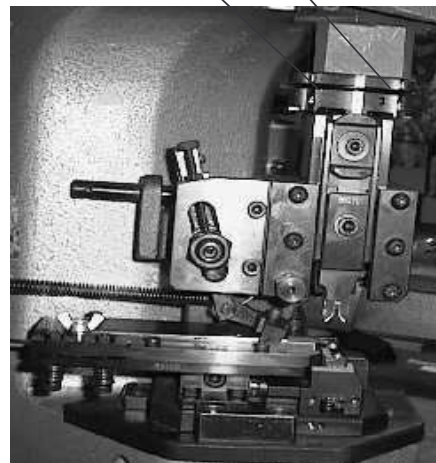

MKS-L

.5 Die Part Replacement

The crimping dies are consumable parts. When a die part becomes worn and requires replacement, check the part number engraved on the die part, or consult the 'exploded view' drawing supplied with every applicator and order a new part from JST technical Services Department.

If you consider that the replacement process is too difficult, or the tooling has sustained damage, please contact JST to either send back the tooling for repair or alternatively a JST Service Engineer can visit your company to repair the tool on site.

6.6 Lubrication of Applicator

Periodically lubricate the surfaces indicated on the photographs with grease. A general purpose grease obtainable from Garages or car accessory shops is suitable.

Remove the ram from the applicator body and apply the grease to the cam surface.

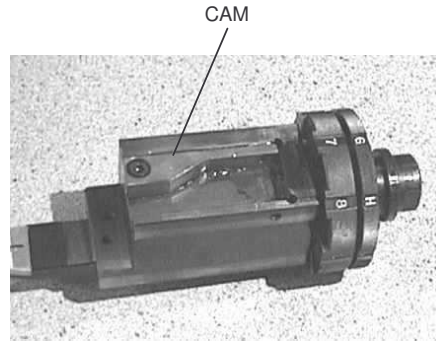

CAM-ROLLER

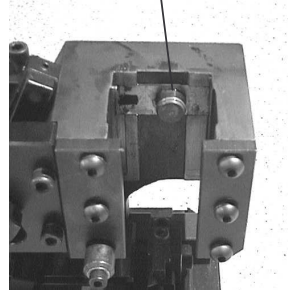

Apply grease to the surface of the cam-roller.

APPLY GREASE HERE

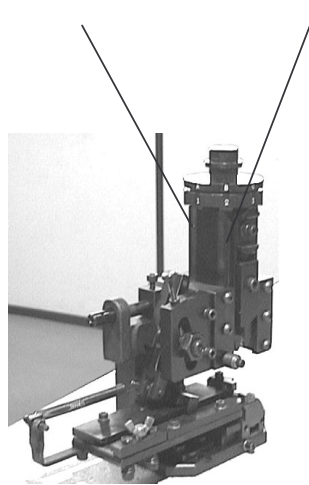

Apply grease to the four faces of the applicator ram.

CAUTION

Apply grease sparingly because excess grease attracts dirt and scrap insulation etc.

7. CRIMPING MACHINE MAINTENANCE

CAUTION

Disconnect the Power Cable from the mains supply before carrying out any maintenance operations on the Crimping Press.

7.1 Lubrication

MAIN SHAFT BEARING

Lightly grease the main-shaft bearing once a year using a general purpose grease, eg Castrol LM.

RAM SECTION

Remove the cap head socket screws from the ram cover and add a few drops of machine oil to the felt pads in the three oiling holes once a week.

CLUTCH SECTION

Remove the cap head socket screws from the belt-cover catch and open the cover. Add a few drops of oil to the oiling points indicated on the photograph.

NOTE: The frequency of lubrication is dependant on the use of the machine. Do not apply excessive lubrication because the oil may drip through onto the applicator and contaminate the terminals.

ROLLER CLUTCH

Step 1

Slowly rotate the fly-wheel whilst pulling the V-belts to the side to remove them.

CAUTION

ENSURE THAT FINGERS DO NOT BECOME TRAPPED BETWEEN THE V-BELT AND THE FLY-WHEEL

Step 2

With the aid of a pair of internal circlip pliers, remove the circlip retaining the fly-wheel.

MAIN SHAFT BEARING GREASING LOCATION

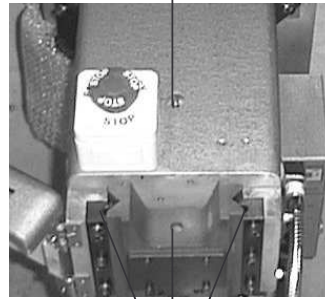

RAM SECTION OILING LOCATIONS

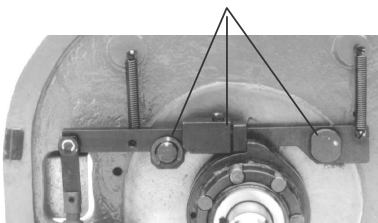

CLUTCH SECTION OILING LOCATIONS

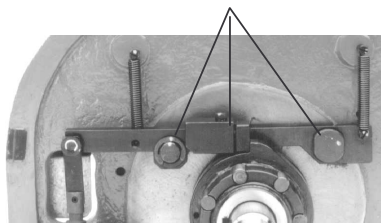

Step 3

Firmly grip the fly-wheel on both sides and pull off the end of the shaft. There are seven 'stick rollers' inside the clutch and they may fall out when the fly-wheel is pulled off the shaft, so take care not to lose any.



Step 4

Remove any traces of old grease from all components of the clutch mechanism and sparingly lubricate all the clutch components with fresh grease.

Specified Grease: Multemp PS no.1 manufactured by Kyodo Yushi Co Ltd.

Do not use general purpose grease because the clutch will not function correctly.

Contact JST Technical Services Department for details of grease stockists.

Step 5

Assemble the clutch ensuring that the clutch lever is engaged correctly with the clutch cam, as in photo A.



PHOTO A

If the clutch is assembled as in photo B, it will not be possible to re-mount the flywheel onto the shaft.



PHOTO B

7.2 Inspection and Repair

RAM STABILITY

Approximately every six months physically check that the ram is not loose.

To check the ram, remove the screws from the catch and open the cover.

Grip the ram firmly and try to move the ram from side to side. It is also possible to detect whether the ram is loose by the noise it makes when crimping, and also the measured crimp height of the terminal may become unstable.

° **Adjustment Procedure**

Step 1

Remove the two dome-nuts from the side wall of the ram.

Step 2

Loosen the three cap head screws on the right hand side of the adjustable ram guide.

Step 3

Fasten the grub screws on the ram guide finger-tight so that you can manually move the ram up and down by hand, but it does not drop under its own weight. Next, check that the ram does not wobble and that it moves smoothly.

Make a final check check that the ram is stable and the screws are secure. Replace cap head screws in ram cover.

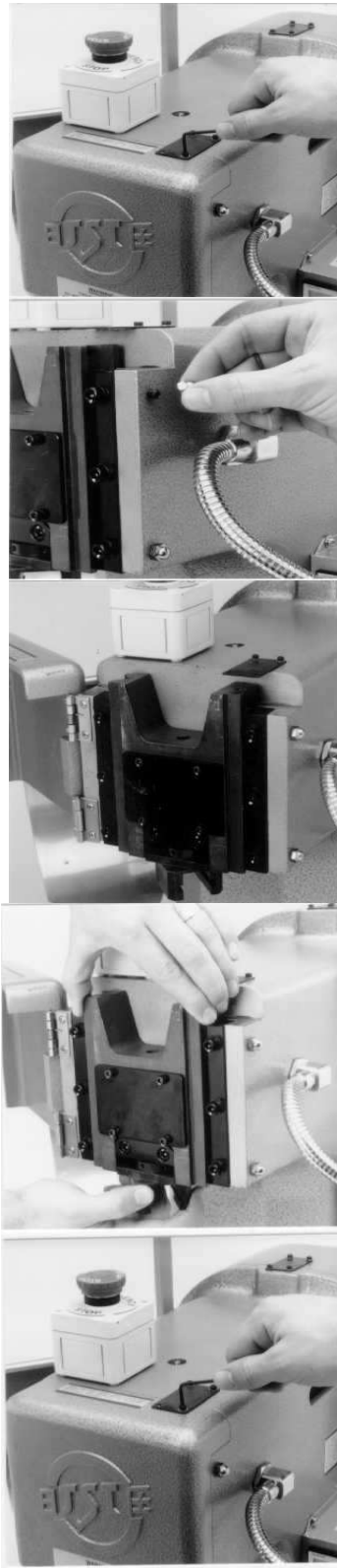

□ Positioning of the Solenoid Bracket

Once a year remove the cap head screws from the catch on the belt cover and open the cover.
Check that the clearance is correct as shown on the photograph.
The clearance should be 6 - 7mm, if it varies from this dimension adjust the bracket in the following manner:-

Loosen the two cap head screws holding the bracket to the press casting and move the solenoid up or down until the correct clearance is obtained.
Tighten the cap head screws on the retaining bracket, close the belt cover and replace the socket screws in the bracket.

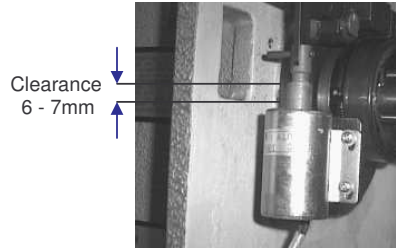

8. FAULT-FINDING

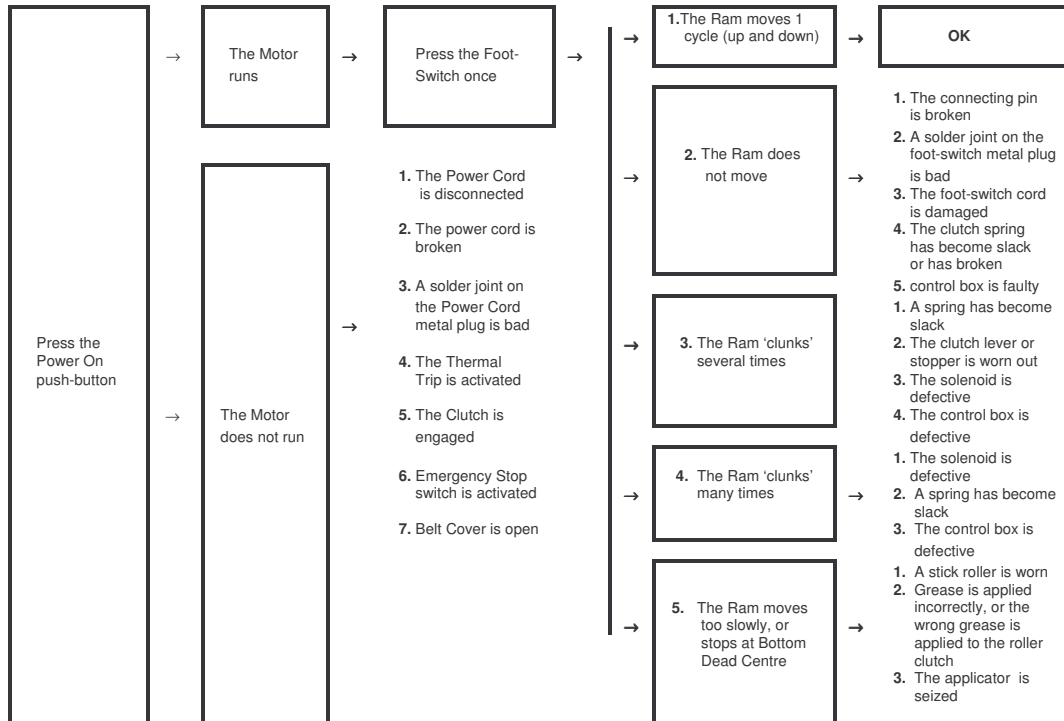

1. The Motor does not run

- (1) **The Power cord is disconnected**
reconnect the power cord.
- (2) **The Power cord is damaged**
replace the power cord



- (3) **A solder joint on the Power Cord metal plug is bad**
Resolder the joint

- (4) **The Thermal Trip is activated**
Press in the thermal trip push-button. If the thermal trip has activated, wait one minute or more before resetting. Consult the JST Technical Department if the thermal trip activates frequently.



- (5) **The Emergency Stop switch is activated**
Reset by turning the switch clockwise

- (6) **The Belt Cover is open**
Close the belt cover and re-secure the catch with the cap head socket screws.



2. The Ram does not move

- (1) **The Connecting Pin is broken**
Replace the connecting pin with a new one.
Connecting pin

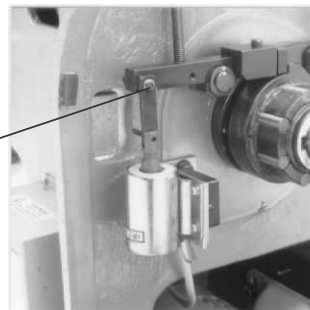

- (2) **A solder joint on the Foot-Switch metal plug is bad**
Resolder the joint



- (3) **The Foot-Switch cord is damaged**
Replace the Foot-Switch cord with a new one.
Connect the micro-switch to the plug as per the illustration.

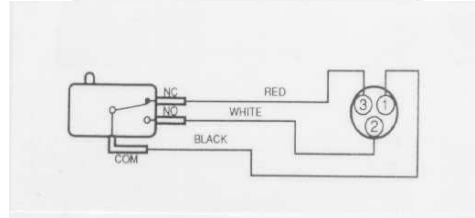

- (4) **The Clutch Spring has become slack or has broken**
Replace the spring with a new one.
- (5) **The Control Box is faulty**
The Control Box requires repair. Contact the JST Technical Services Department for assistance.

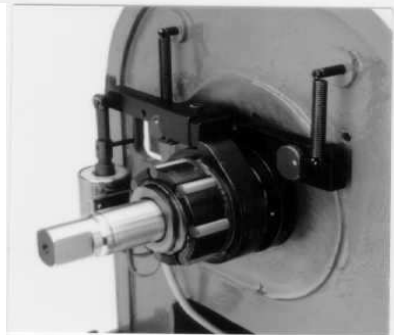

3. The Ram 'clunks' several times

- (1) **A Spring has become slack**
Replace the spring with a new one.

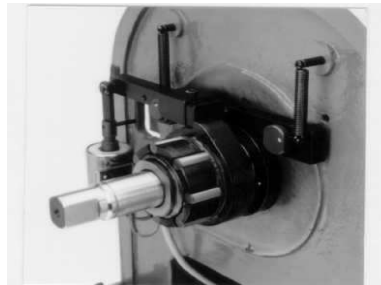

- (2) **The Clutch Lever or Stopper is worn out**
Replace parts with new ones.



- (3) **The Solenoid is defective**
Adjust the relationship between the solenoid piston and cylinder by moving the solenoid cylinder back or forth on the solenoid bracket.



- (4) **The Control Box is defective**
The control box requires repair. Contact the JST Technical Services Department for assistance.

4. The Ram 'clunks' many times

- (1) **The Solenoid is defective**
Refer to 3-(3) above.
- (2) **A Spring has become slack**
Replace the spring with a new one, see 3-(1).
- (3) **The Control Box is defective**
The control requires repair. Contact JST Technical Services Department for assistance.

5. The Ram moves too slowly, or stops at Bottom Dead Centre

- (1) **A Stick Roller is worn out**
Replace the stick rollers with new ones. Always replace the rollers as a set of seven. Oversize rollers are available from JST to extend the service life of the clutch. Please contact the Technical Services Department for details.
- (2) **Grease is applied incorrectly, or the wrong grade of grease has been used**
Clean the clutch and reapply the correct grade of grease. See section 7 for details of grease specification.
- (3) **The Applicator is seized**
Contact the JST Technical Services Department for assistance.
- (4) **Part of the Clutch assembly is missing**
Check that all the Stick Rollers are assembled.

No.	Part Name	Part No.
101	Body	K2-1101
105	Motor plate	K2-4105
106	Belt cover	K2-2106
107	V-pully	K2-4107
109	V-belt(M-39)	K2-P109
110	Flywheel	K2-3110
111	Back stop cam	K2-3111
112	Spring post	K2-4112
113	Clutch cam	K2-3113
114	Spacer	K2-4114
115	Ball bearing(6205ZZ)	K2-P115
116	Key(8x7x591, both edges rounded)	K2-P116
117	Retaining ring(C-25)	K2-P117
118	Retaining ring(C-52)	K2-P118
120	Outside clutch ring	K2-4120
121	Stick roller	K2-4121
122	Plate	K2-4122
124	Inside clutch cam	K2-4124
125	Retaining ring(C-62)	K2-P125
126	Retaining ring(C-30)	K2-P126
127	Ball bearing(6206ZZ)	K2-P127
128	Retaining ring(C-40)	K2-P128
129	Needle bearig(NA5908)	K2-P129
130	Main shaft	K2-3130
131	Bush	K2-4131
132	Ram cover	K2-3132
135	Pressure plate	K2-4135
136	Split nut	K2-4136
137	Adjustment screw	K2-4137
138	Ram head	K2-3138
141	Hexagon box nut M6 type-1, 3 shapes	K2-P141
145	Adjustment ram guide	K2-3145
147	Ram	K2-3147
148	Fixed ram guide	K2-3148
152	Fulcrum pin	K2-4152
153	Back stop lever	K2-4153
154	Spring post	K2-4154
155	Spring	K2-4155
156	Stopper	K2-4156
157	Pad	K2-4157
159	Clutch lever	K2-3159
160	Fulcrum pin	K2-4160
161	Collar	K2-4161
162	E-shaped retaining ring(ϕ 9)	K2-P162
163	Spacer	K2-4163

No.	Part Name	Part No.
164	Connecting pin	K2-4164N
165	Connecting plate	K2-4165N
166	Solenoid bracket	K2-4166N
167	Spring-loaded hinge	K2-P167
173	Reel hanger	K2-3173
175	Reel guide	K2-4175
176	Solenoid	K2-P176
177	Spring post	K2-4177
178	Spring	K2-4178
179	Spring post	K2-4179
180	Terminal guide	K2-4180
181	Hand crank	K2-3181
182	Grip bar	K2-4182
183	Reel collar	K2-4183
185	Reel rod	K2-4185
186	Elbow	K2-4186
187	Nut	K2-4187
190	Motor(SP-KR, 200W, by Mitsubishi)	K2-P190
192	Positioning block	K2-4192
193	Applicator guide(for fixing)	K2-4193
194	Applicator guide(for guiding)	K2-4194
196	Applicator base	K2-P196
198	Operation light	K2-P198
201	Needle bearing(NTN RNA49/32R)	K2-P201
212	Photo microsensor mounting eye	K2-4212N
213	Photo microsensor(EE-SX672, by Omron)	K2-P213
214	Socket(EE-1001, by Omron)	K2-P214
216	Rear cover detecting plate	K2-4216N
219	Rivet(No. 2x4, 8)	K2-P219
220	Spring pin(3x22)	K2-P220
223	E-shaped retaining ring(ϕ 3)	K2-P223
224	Flat hinge(B43/SUS-1, by Takesita Kinzoku)	K2-P224
230	Name plate	K2-4230N
225	Solenoid cover	K2-4225UK
226	Crank hole cover	K2-4226UK
227	Slit cover	K2-4227UK
228	Cover catch	K2-4228UK

No.	Part Name	Part No.
500	Control box(ASS' Y)	K2-3500
501	Control box	K2-3501
502	PCB(9006A, ASS' Y)	K2-3502
503	PCB(9006B, ASS' Y)	K2-3503
504	PCB(9006C, ASS' Y)	K2-3504
505	Counter	K2-P505
506	Circuit protector	K2-P506
507	Operation light switch	K2-P507
508	Transformer	K2-P508
509	Solid state relay	K2-P509
510	Metal socket(POWER)	K2-P510

No.	Part Name	Part No.
511	Metal socket(F/S)	K2-P511
512	Power cord(ASS' Y)	K2-P512
513	Foot switch cord(ASS' Y)	K2-P513
514	PCB(9006A)	K2-4502-1
515	PCB(9006B)	K2-4503-1
516	Reset pushbutton	K2-P503-1
517	PCB(9006C)	K2-4504-1
518	Power ON pushbutton	K2-P504-2
519	Power OFF pushbutton	K2-P504-3
520	Socket	K2-P504-5
550	E. S. ASS' Y	K2-P550UK

Note: Nos. 501 through 511, and Nos. 514 through 520 are not shown in the diagram.

The Applicator MK-L

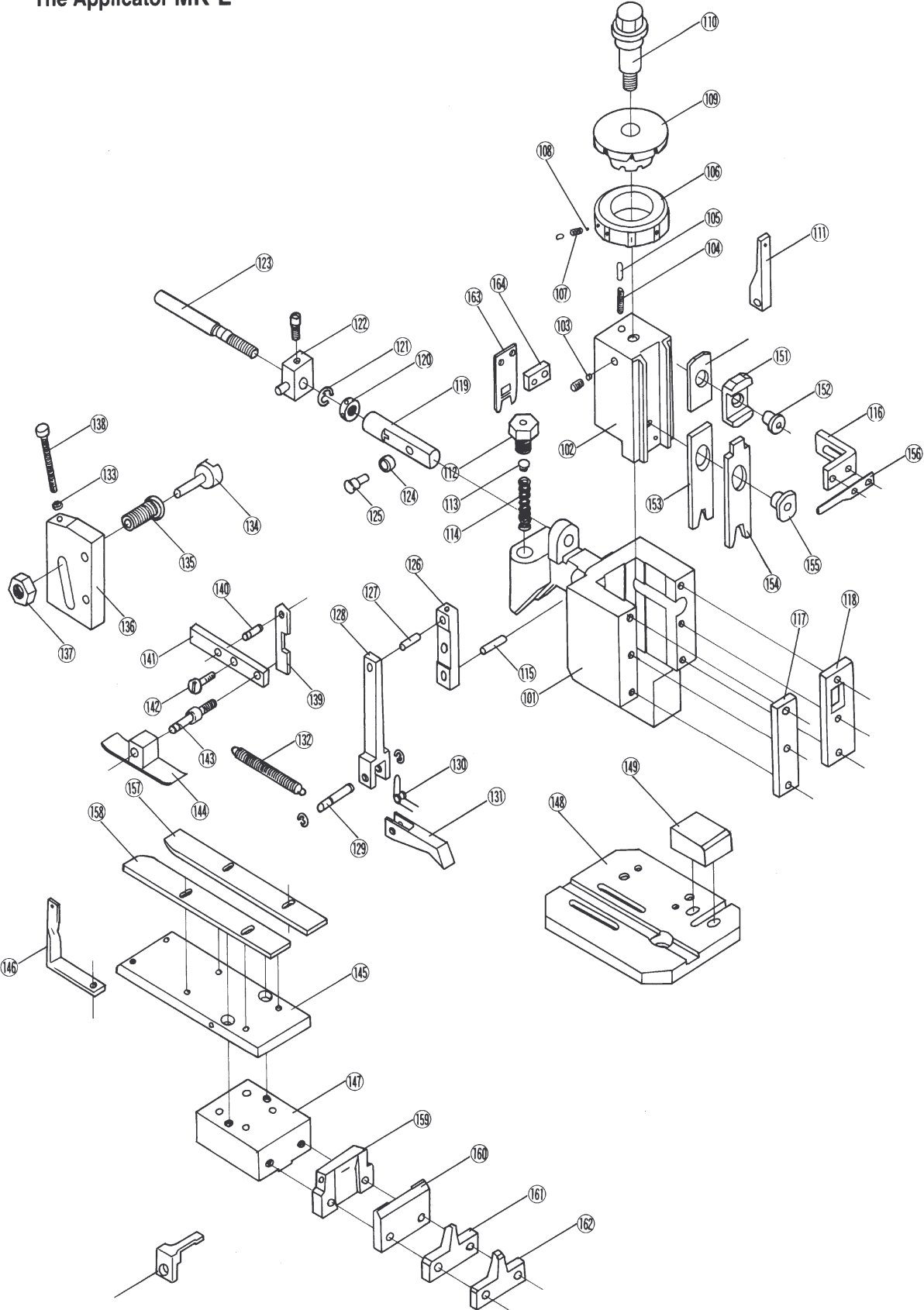

Parts list for the applicator MK-L

No.	Part Name	Part No.	No.	Part Name	Part No.
101	Body	MA02-101	133	Hex. Nut M4 type-1	
102	Slider	MA02-210	134	Stroke adj. Shaft	MA01-331
103	Copper bar (3.8Øx2mm)		135	Stroke adj. Bearing	MA01-332
104	Positioning spring	MA01-214	136	Stroke adj. Plate	MA02-330
105	Positioning pin	MA01-213	137	Hex. Nut	MA01-333
106	Insulation disk	MA01-215	138	Stroke adj. Screw	MA01-334
107	Spring	MA01-216	139	Hook	MA01-475
108	Steel ball		140	Hook pin	MA01-476
109	Wire disk	MA01-211	141	Release lever	MA01-473
110	Shank	MA01-217	142	Release lever pin	MA01-474
111	Cam	MA02-335	143	Pressure pad pin	MA01-472
112	Spring cap	MA01-477	144	Pressure pad	MA01-470
113	Spring block	MA01-479	145	Feed plate	
114	Spring	MA01-480	146	Spring anchor	MA01-350
115	Support pin	MA01-343	147	Die block	MA01-105
116	Stripper hanger	MA02-481	148	Die plate	MA02-104
117	Plate (L)	MA02-102	149	Side block	MA02-107
118	Plate (R)	MA02-103	150	Wire block	
119	Feed shaft	MA01-338	151	Insulation block	
120	Ring nut	MA01-341	152	Block ring	MA01-225
121	E-shaped ret. ring (6Ø)		153	Crimper (A)	
122	Lever block	MA01-340	154	Crimper (B)	
123	Adj. Bolt	MA01-339	155	Die holder ring	
124	Cam roller	MA01-308A	156	Stripper	
125	Cam roller shaft	MA01-337A	157	Guide plate (R)	
126	Feed lever (A)	MA01-342	158	Guide plate (L)	
127	Feed lever pin	MA01-344	159	Shear blade anvil (A)	
128	Feed lever (B)	MA01-345	160	Shear blade anvil (B)	
129	Feed finger pin	MA01-347	161	Crimper anvil (A)	
130	Feed finger spring	MA01-348	162	Crimper anvil (B)	
131	Feed finger		163	Shear blade	
132	Returning spring	MA01-349	164	Spacer	

The Applicator MKS-L

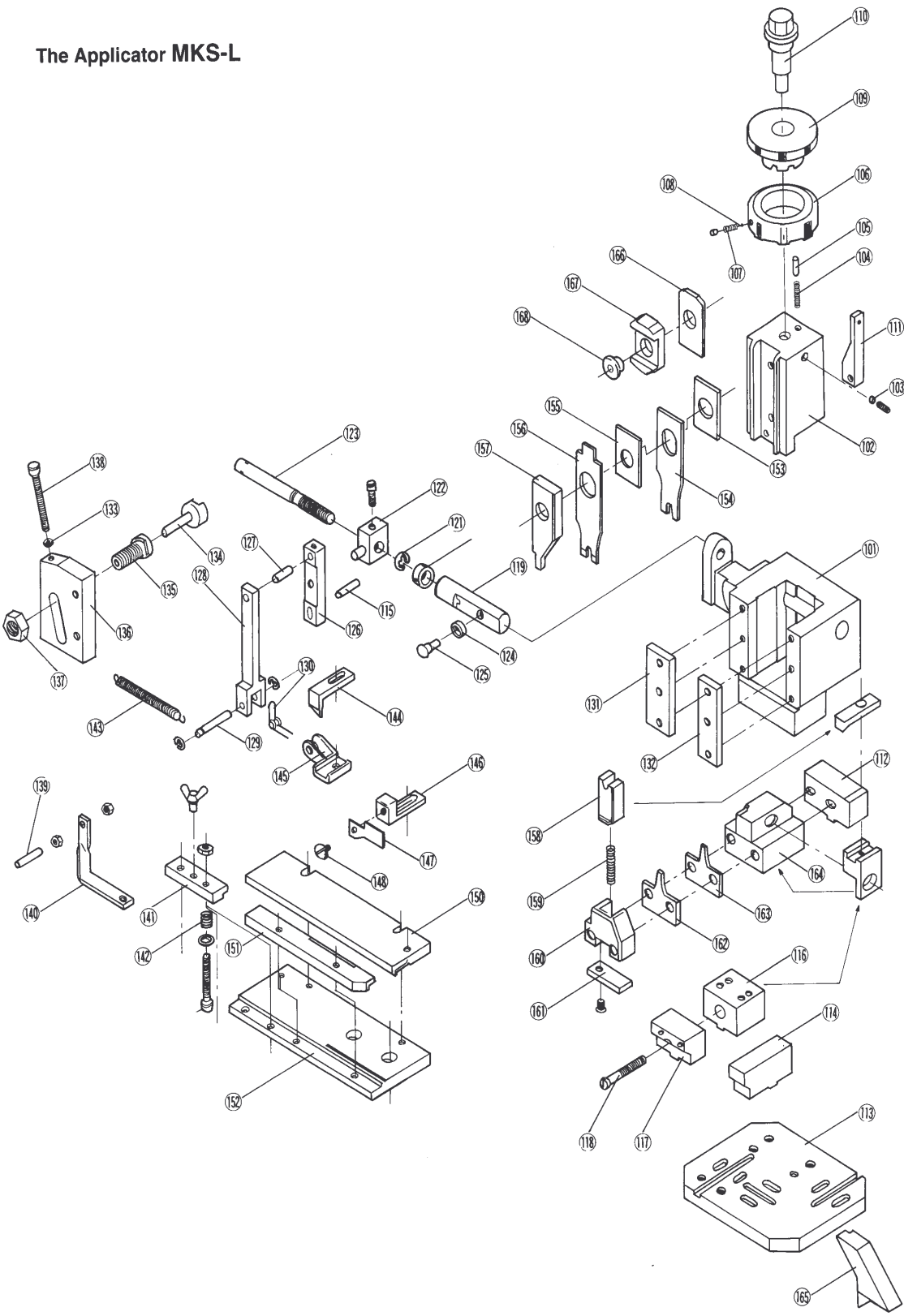

Parts list for the applicator MKS-L

No.	Part Name	Part No.	No.	Part Name	Part No.
101	Body	MA03-101	135	Stroke adj. Bearing	MA01-332
102	Slider	MA03-210	136	Stroke adj. Plate	MA03-330
103	Copper bar (3.8Øx2mm)		137	Hex. Nut	MA01-333
104	Positioning spring	MA01-214	138	Stroke adj. Screw	MA01-334
105	Positioning pin	MA01-213	139	Spring anchor pin	MA03-352
106	Insulation disk	MA01-215	140	Spring anchor	MA03-350
107	Spring	MA01-216	141	Pressure plate	
108	Steel ball (3Ø)		142	Pressure spring	
109	Wire disk	MA01-211	143	Returning spring	MA03-349
110	Shank	MA01-217	144	Feed finger	
111	Cam	MA03-335	145	Feed finger holder	
112	Die block	MA03-105	146	Stripper bracket	
113	Die plate	MA03-104	147	Stripper	
114	Side block	MA03-107	148	Stripper screw	
115	Support pin	MA01-343			
116	Feed plate base	MA03-106	150	Guide plate (R)	
117	Adj. Plate	MA03-108	151	Guide plate (L)	
118	Adj. Screw	MA03-109	152	Feed plate	
119	Feed shaft	MA01-338	153	Spacer	
120	Ring nut	MA01-341	154	Crimper (A)	
121	E-shaped ret ring (6Ø)		155	Spacer	
122	Lever block	MA01-340	156	Crimper (B)	
123	Adj. Screw	MA03-339	157	Punch	
124	Cam roller	MA01-308A	158	Shear blade	
125	Cam roller shaft	MA01-337A	159	Shear blade spring	
126	Feed lever (A)	MA01-342	160	Shear blade supporter	
127	Feed lever pin	MA01-344	161	Shear blade base	
128	Feed lever (B)	MA01-345	162	Crimper anvil (B)	
129	Feed finger pin	MA01-347	163	Crimper anvil (A)	
130	Feed finger spring	MA01-348	164	Spacer	
131	Plate (L)	MA03-102	165	Scrap cover	
132	Plate (R)	MA03-103	166	Wire block	
133	Hex. Nut (M4, type-1)		167	Insulation block	
134	Stroke adj. shaft	MA01-331	168	Block ring	MA01-225

The Applicator MKF-L

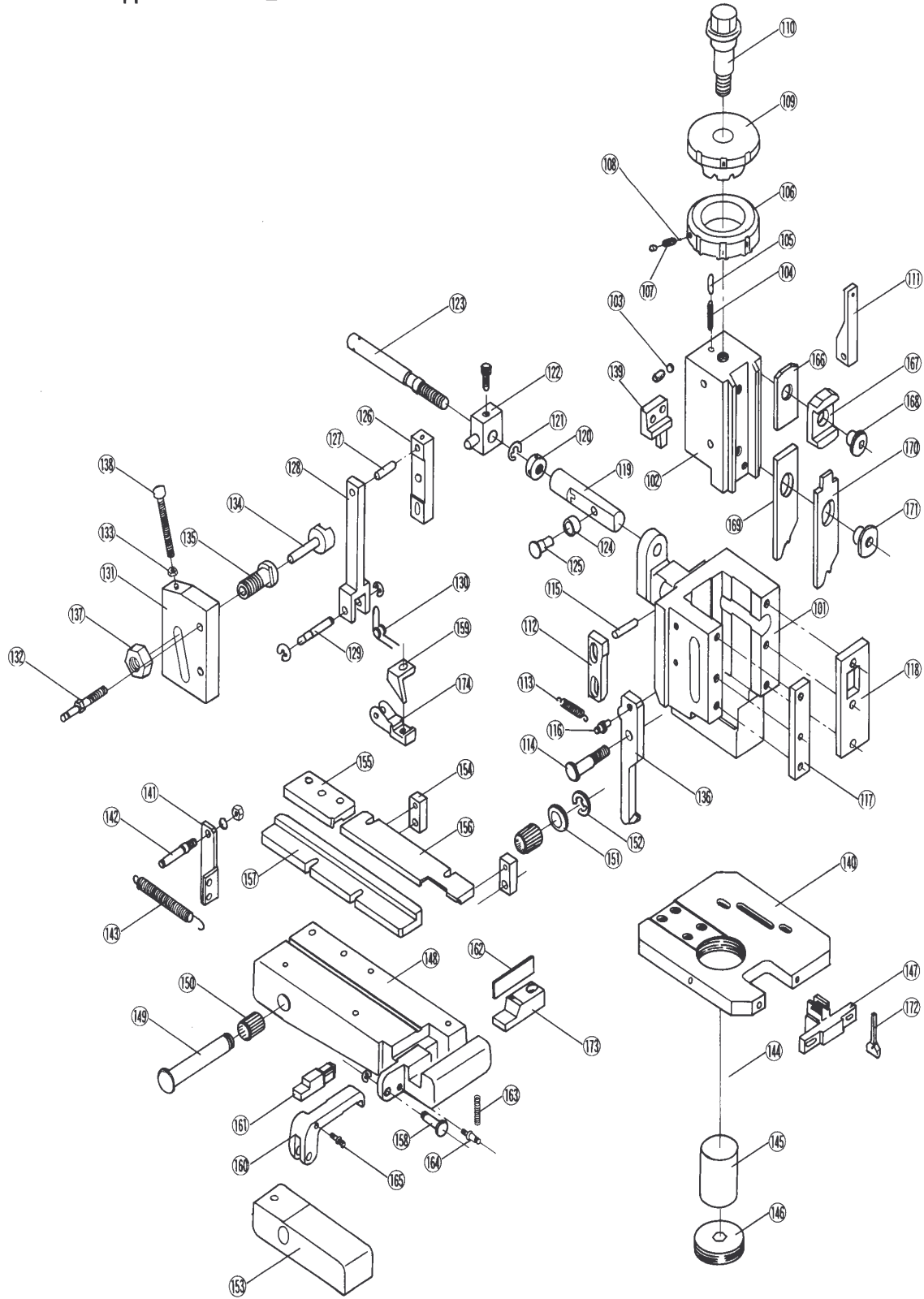

Parts list for the applicator MKF-L

No.	Part Name	Part No.	No.	Part Name	Part No.
101	Body	NF-2101	138	Stroke adj. Screw	MA01-334
102	Slider	NF-3118	139	Punch	NF-4122
103	Copper bar (3.8Øx2mm)		140	Die plate	NF-3149
104	Positioning spring	MA01-214	141	Bracket	NF-4133
105	Positioning pin	MA01-213	142	Spring post	NF-4159
106	Insulation disk	NF-4121	143	Returning spring	MA03-349
107	Spring	MA01-216	144	Spring	NF-4126N
108	Steel ball (3Ø)				
109	Wire disk	MA01-211	146	Keep plate	NF-4125
110	Shank	MA01-217	147	Crimper anvil base	NF-4105
111	Cam	NF-4168	148	Feed plate	NF-2129*
112	Guide shoe	NF-4140	149	Support pin	NF-4163
113	Tension spring	NF-4117	150	Needle bearing K12x15x13	NF-B164
114	Fulcrum bolt	NF-4115	151	Collar	NF-4154
115	Support pin	MA01-343	152	E-shaped ret.ring (9Ø)	
116	Spring post	NF-4116	153	Guide block	NF-4165
117	Plate (L)	NF-4114	154	Holder block	NF-4147
118	Plate (R)	MA02-103	155	Pressure plate	
119	Feed shaft	MA01-338	156	Guide plate (R)	
120	Ring nut	MA01-341	157	Guide plate (L)	
121	E-shaped ret.ring (6Ø)		158	Pin	NF-4109
122	Lever block	MA01-340	159	Feed finger	
123	Adj. Bolt	MA01-339	160	Shear blade	
124	Cam roller	MA01-308A	161	Shear blade anvil (A)	
125	Cam roller shaft	MA01-337A	162	Shear blade anvil (B)	
126	Feed lever (A)	MA01-342	163	Tension spring	NF-4110
127	Feed lever pin	MA01-344	164	Spring post	NF-4108
128	Feed lever (B)	NF-4138	165	Spring post	NF-4111
129	Feed finger pin	MA01-347	166	Wire block	
130	Feed finger spring	MA01-348	167	Insulation block	
131	Feed adj. Plate	NF-4137	168	Block ring	MA01-225
132	Spring post	NF-4139	169	Crimper (A)	
133	Hex. Nut (m4,type-1)		170	Crimper (B)	
134	Stroke adj. Shaft	MA01-331	171	Die holder ring	
135	Stroke adj. Bearing	MA01-332	172	Crimper anvil (A)	
136	Hook	NF-4113	173	Crimper anvil (B)	
137	Hex. Nut	MA01-333	174	Finger holder	

The Applicator MKS-LS

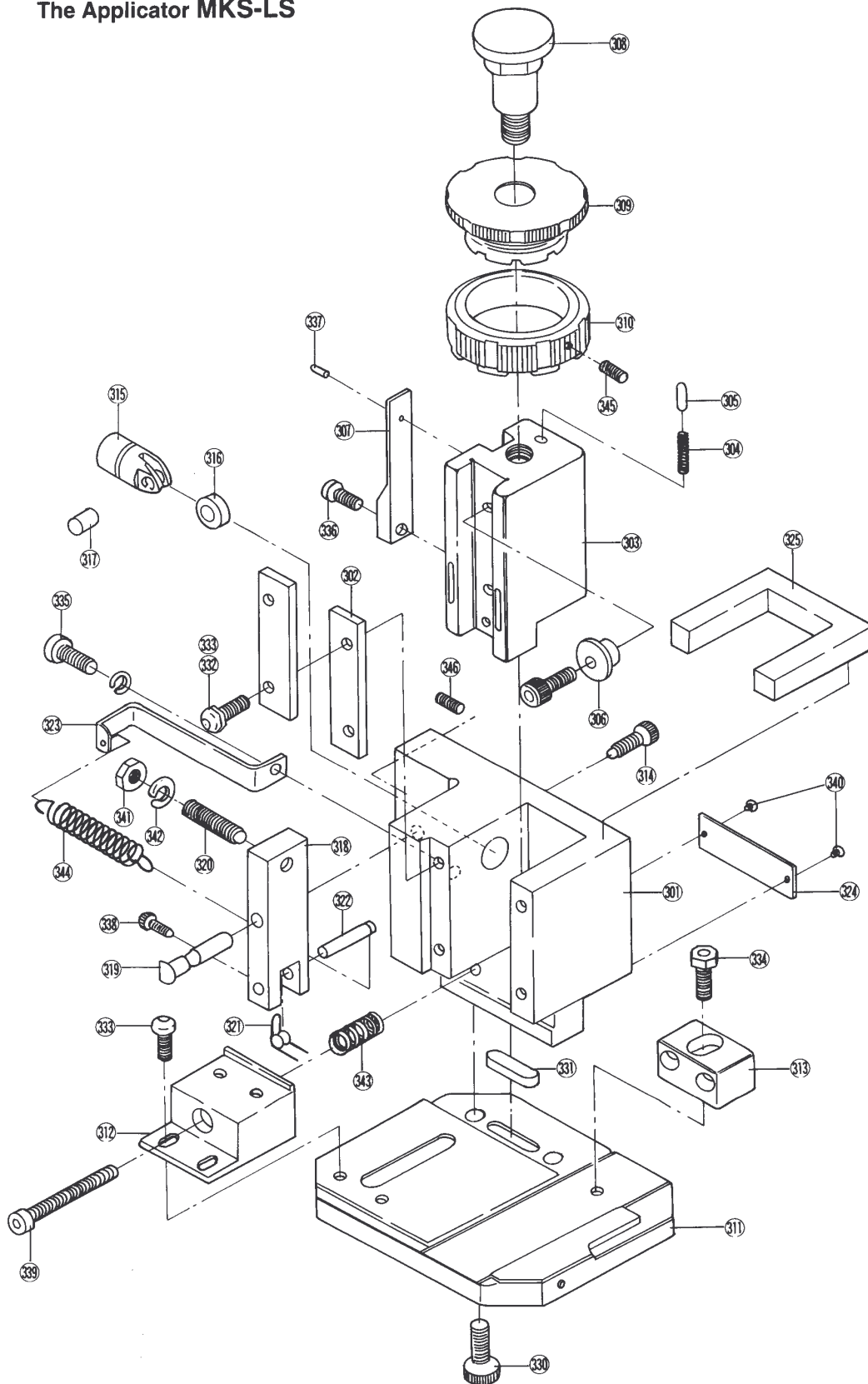

Parts list for the applicator MKS-LS

No.	Part Name	Part No.
301	Body	LS-2301
302	Plate	LS-4302
303	Slider	LS-3303
304	Positioning spring	MA01-214
305	Positioning pin	MA01-213
306	Block ring	MA01-223
307	Cam	LS-4307
308	Shank	LS-4308
309	Wire disk	LS-4309
310	Insulation disk	LS-4310
311	Die plate	LS-3311
312	Feed plate base	LS-4312
313	Die block	LS-4313
314	Retaining bolt	LS-4314
315	Feed shaft	LS-4315
316	Cam roller	LS-4316
317	Pin	LS-4317
318	Feed lever	LS-4318
319	Feed lever pin	LS-4319
320	Adj. Screw	112-223
321	Feed finger spring	MA01-348
322	Feed finger pin	LS-4322
323	Hook	LS-4323
324	Name plate	LS-4324
325	Protection rubber	LS-4325
330	Hex. Socket head bolt (M6x18)	
331	Key (6x6x25 round ends)	LS-B331
332	Spring washer (5)	
333	Button head screw (M5x12)	
334	Hex. Socket head bolt (M5x18)	
335	Hex. Socket head bolt (M5x10)	
336	Hex. Socket head bolt (M4x8)	
337	Pin (2x4)	
338	Hex. Socket head bolt (M3x6)	
339	Hex. Socket head bolt (M5x50)	
340	Rivet (1.5Øx5)	
341	Hex. Nut (M6, type-1)	
342	Spring washer (6)	
343	Compressed coil spring	LS-B343
344	Tension spring	LS-B344
345	Ball plunger	LS-B345
346	Hex. Socket head screw (M4x10)	

Notes:

Offices World-Wide

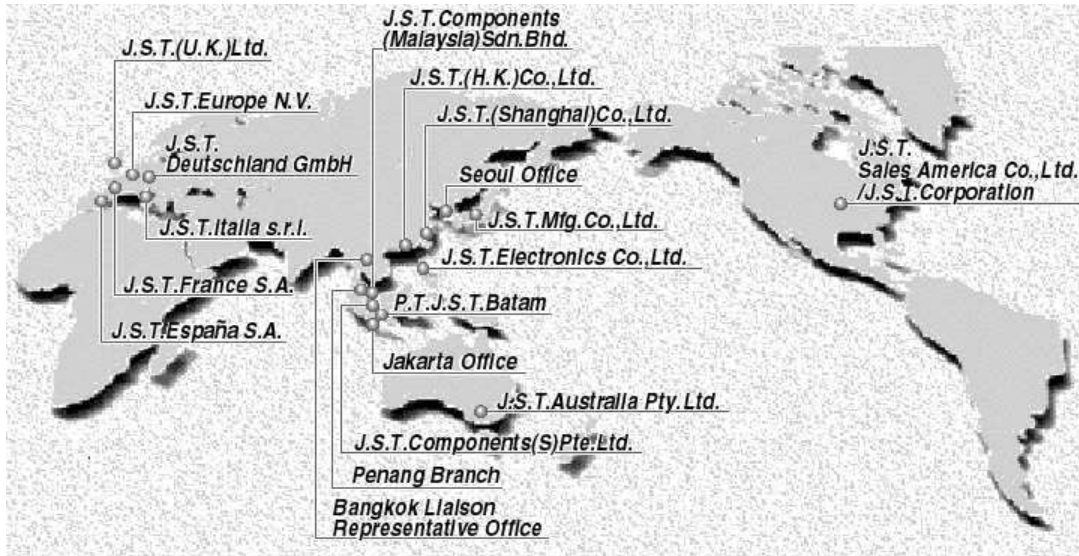

HEAD OFFICE: J.S.T. MFG. CO., LTD. 2-6-8, Shigino-nishi, Joto-ku, Osaka, 536-0014 JAPAN.
 Phone: (06) 6968-6855 / Int'l 81-6-6968-6855 Fax<G4>: (06) 6964-2085 / Int'l 81-6-6964-2085

U.K.	Tel: 44 \ 0 \ 1986 87 4131		Tel: 32 \ 0 \ 1660 0525
	Fax: 44 \ 0 \ 1986 87 4276	Belgium	Fax: 32 \ 0 \ 1660 5877
	Tel: 33 \ 3 \ 2672 4503		Tel: 49 \ 0 \ 7181 4007 0
France	Fax: 33 \ 3 \ 2672 1088	Germany	Fax: 49 \ 0 \ 7181 4007 21
Italy	Tel: 39 \ 02 \ 9390 0418	Spain	Tel: 34 \ 93 \ 564 2120
	Fax: 39 \ 02 \ 9390 0421		Fax: 34 \ 93 \ 564 8266
Singapore	Tel: 65 \ 743 0405	Thailand	Tel: 66 \ 2 \ 693 2905
	Fax: 65 \ 746 1787 [G4]		Fax: 66 \ 2 \ 693 2906
Malaysia #1	Tel: 60 \ 0 \ 3 755 4620	Indonesia #1	Tel: 62 \ 0 \ 7 7061 1685
	Fax: 60 \ 0 \ 3 758 3802		Fax: 62 \ 0 \ 7 7061 1684
Malaysia #2	Tel: 60 \ 0 \ 4 226 7258	Indonesia #2	Tel: 62 \ 0 \ 21 575 0816
	Fax: 60 \ 0 \ 4 226 7269		Fax: 62 \ 0 \ 21 575 0803
Honk Kong	Tel: 85 2 \ 2413 7979	China	Tel: 86 \ 21 5866 3418
	Fax: 85 2 \ 2411 1193		Fax: 86 \ 21 5866 3421
Korea	Tel: 8 \ 0 \ 2 2527 3334/3335	Taiwan	Tel: 886 \ 0 \ 2 2531 8500
	Fax: 8 \ 0 \ 2 2527 3336		Fax: 886 \ 0 \ 2 2531 8485
U.S.A.	Tel: 1 \ 847 \ 473 1957	Australia	Tel: 61 \ 0 \ 3 9877 6444
	Tel: 1 \ 800 947 1110 (toll free)		Fax: 61 \ 0 \ 3 9877 6395
	Fax: 1 \ 847 \ 473 0144 [G4]		

For full up to date address details go to: www.jst-mfg.com/e00com/e31com.html

In line with a policy of continual development JST reserves the right to change the specifications of the goods described in this manual at any time and without prior notice.