

LOC	DIST	REVISIONS			
P	LTR	DESCRIPTION	DATE	DWN	APVD
AF	50	E	REVISED PER OG3A-0770-02	17JAN03	MF GP

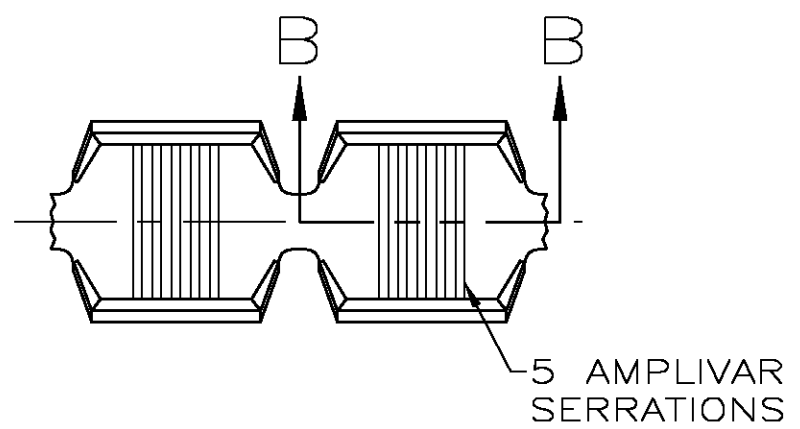

- 1 CONTINUOUS STRIP ON REELS
- 2 CRIMP WIDTH: .180 F TYPE (AMPLIVAR THRU)
 CRIMP HEIGHT (±.002) = (TOTAL CMA + 23,000) / 312,500
 GENERAL APPLICATION GUIDELINES MUST BE FOLLOWED AS SPECIFIED IN CATALOG #82221
 FOR APPLICATOR INFORMATION CALL: 1-800-722-1111
 FOR PRODUCT INFORMATION CALL: 1-800-522-6752

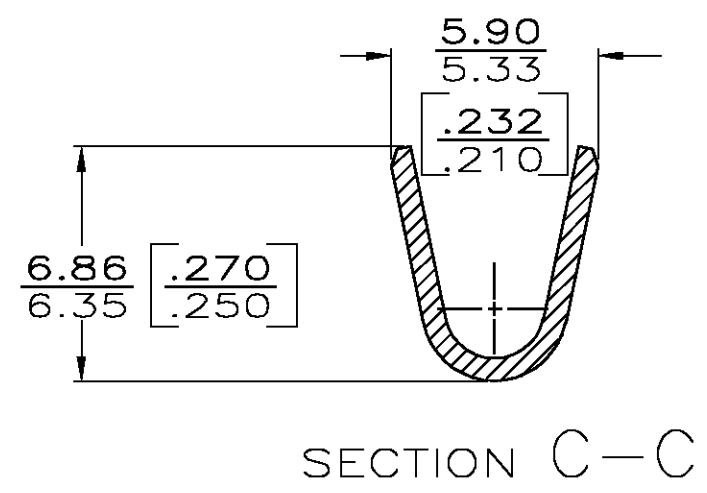
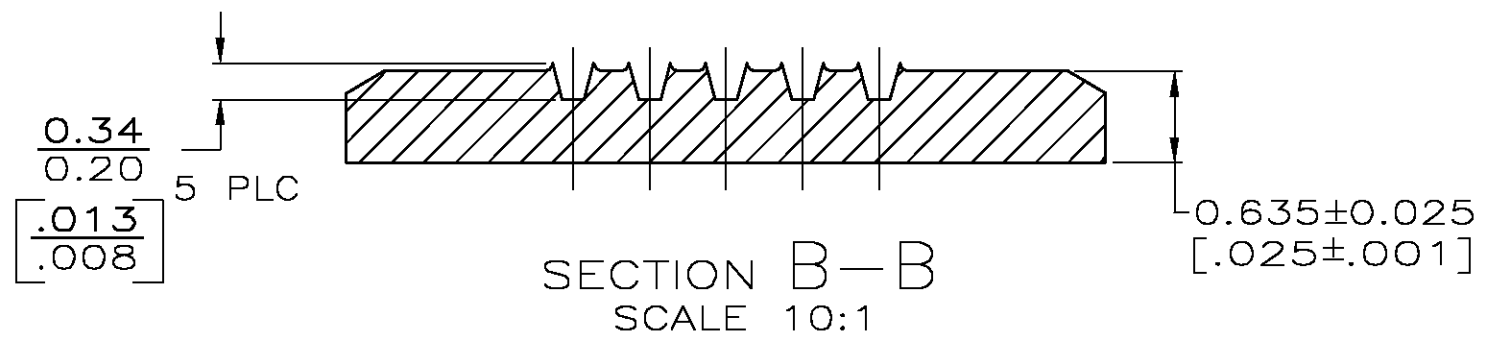
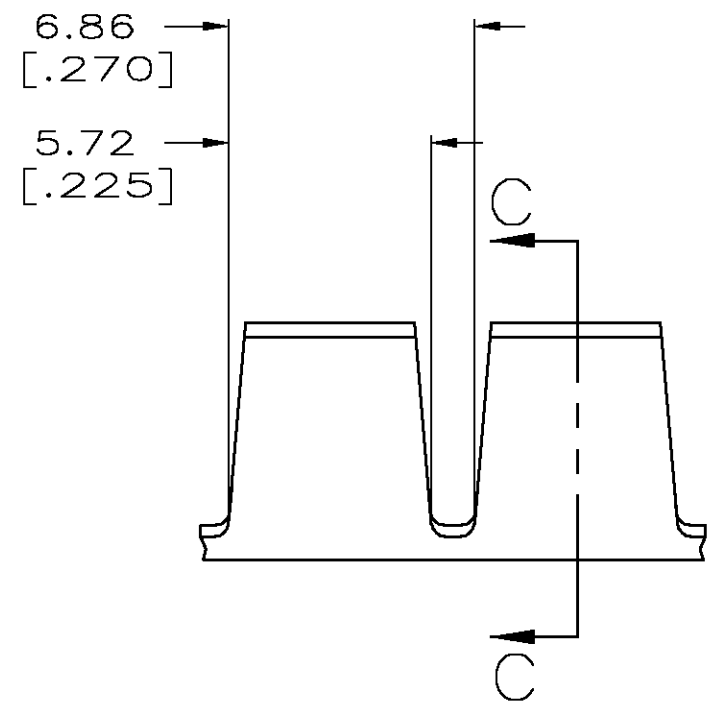

THIS DRAWING IS A CONTROLLED DOCUMENT.

DIMENSIONS:	TOLERANCES UNLESS OTHERWISE SPECIFIED:
mm [INCHES]	↑
	0 PLC ± -
	1 PLC ± -
	2 PLC ± -
	3 PLC ± 0.38 [.015]
	4 PLC ± -
ANGLES	± -
MATERIAL	FINISH
#2 HARD BRASS	-

DWN	P FORTNEY	11/27/89
CHK	MS FEHER	11/29/89
APVD	D.SCHWENK	11/29/89
PRODUCT SPEC	-	-
APPLICATION SPEC	114-2009	-
WEIGHT	-	-
CUSTOMER DRAWING	SCALE 5:1 SHEET 1 OF 1 REV E	

2	7000-13000 CMA	41770
WIRE SIZE		PART NUMBER
Tyco Electronics Corporation Harrisburg, PA 17105-3608		
NAME		
SPLICE, AMPLIVAR		
SIZE	CAGE CODE	DRAWING NO
A3	00779	41770
RESTRICTED TO		-