

版数 REV.	年月日 DATE	DCN NO.	変更内容 DESCRIPTION	製図 DR.	担当 CHK.	査閲 APPD.	承認 APPD.
2	30/MAR/2010	069693	REDRAWN (JAPANESE ⇒ BILINGUAL)	M. SHINOZAKI	G. KAWAMURA	O. Takagi	Y. OTSUKA

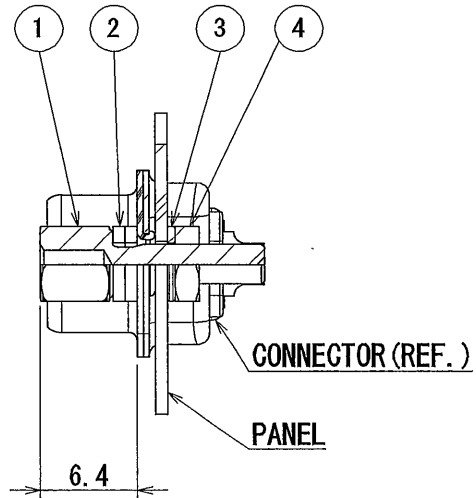

FRONT MOUNTING
(SCALE 2:1)

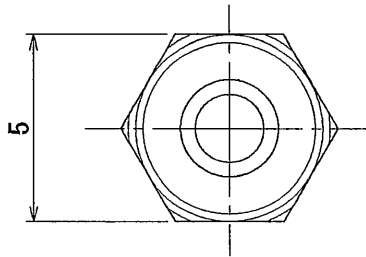
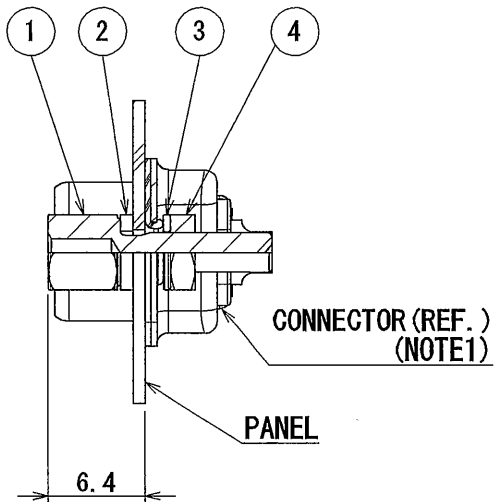
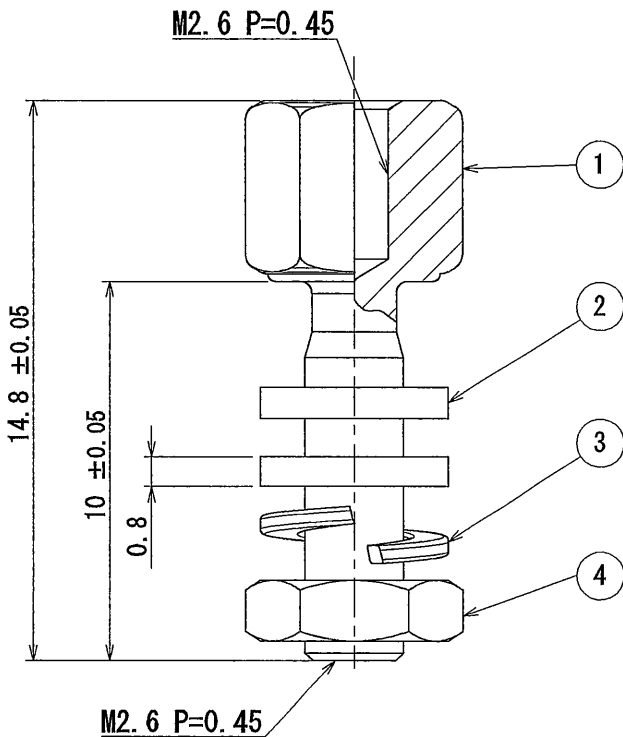

REAR MOUNTING
(SCALE 2:1)

NOTE1. WHEN CONNECTORS ARE REAR-MOUNTED, A WASHER FOR EVERY 0.8MM OF PANEL THICKNESS SHALL BE REMOVED IN MOUNTING SO AS TO KEEP THE DIMENTION OF 6.4MM.
2. PARTS IN ITEMS 2, 3, 4 ARE ATTACHED TO PACKAGE, NOT ASSEMBLED.

4	NUT	1	STEEL	NICKEL PLATING	
3	SPRING WASHER	1	STEEL	NICKEL PLATING	
2	WASHER	2	STEEL	NICKEL PLATING	REFER TO NOTE1
1	LOCKING NUT	1	STEEL	NICKEL PLATING	
符号 NO.	名称 DESCRIPTION	個数 QTY.	材料 MATERIAL	仕上 FINISH	備考 REMARKS

仕様書 (SPECIFICATION)		第1版 (ORIGINAL DATE) 03/MAR/1983		名称 (TITLE) D20418-J3F		日本航空電子工業株式会社 Reference Only		SIZE A4
一般公差 (GENERAL TOLERANCE)		製図 DR.	S. T	シリーズ (SERIES) D-Sub		JAE JAPAN AVIATION ELECTRONICS INDUSTRY, LTD.		
寸法 (DIMENSION)		担当 CHK.	TASHIRO					
角度 (ANGLES)		査閲 APPD.						
. ± —		承認 APPD.	KANEDA	尺度 (SCALE) 5:1		図面番号 (DRAWING NO.) SJ018086		版数 (REV.) 2

DCF-C-211F (05.08)

S/W